

Côté / Side

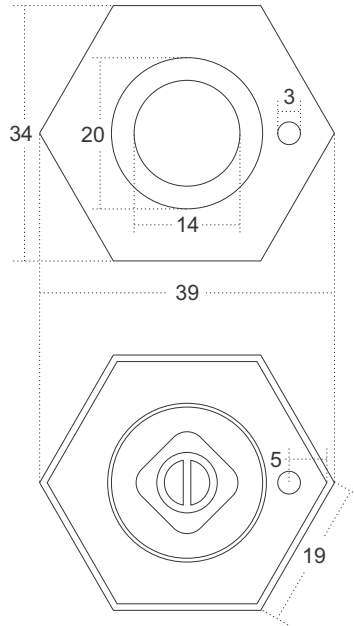

**Nouvel article**  
**New Item**

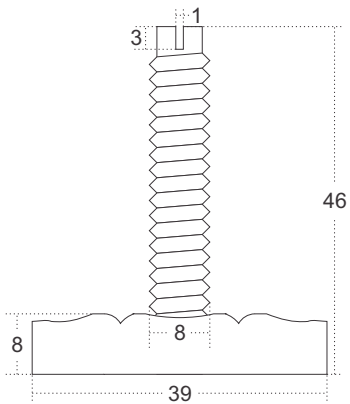

**Renseignements importants / Important Information**

Indication de prix / Price Indication : \$ \_\_\_ ch / ea \$ \_\_\_ ch / ea \$ \_\_\_ ch / ea

Date de départ / Starting Date : 20 JAN 2005 / JAN 25 2005

Marché-cible / Targeted Market : Mobilier de bureau / Office Furniture

Date de cette annonce / Date Announced : 22 NOV 2005

Présenté par / Presented by : \_\_\_\_\_

<b>Produit / Product</b>	<b>Sous-patte ajustable en acier</b> <b>Steel adjustable glide</b>
<b>Engineering #</b>	05112201-GLD-V01
<b>Prod #</b>	
<b>Page(s)</b>	1/ 1(QI.Cat.Pg :TBD)
<b>Échelle / Scale</b>	1: 1(16.6%)
<b>Couleur / Color</b>	Chrome / Chrome
<b>Fini / Finish</b>	
<b>Dimensions</b>	Voir pièces / See parts [ ] cm [X] mm [ ] po / in [ ] ø
<b>Accessoires / Accessories</b>	
<b>Emballé / Packed</b>	
<b>Qté / Qty</b>	
<b>OP</b>	
<b>Date</b>	22.11.2005